



INSTRUCTION MANUAL  
**SRX**  
Square Root Transmitter

Form 110-701-00G

April 2016

---

## 1.1 SCOPE OF MANUAL

This manual contains operating and maintenance information for the Two-Wire Square Root Extractor, (SRX) manufactured by MOORE INDUSTRIES INC., Sepulveda, California. The manual consists of the following six sections:

**Section 1, General Information**, introduces the equipment function and describes the equipment physical appearance, the equipment specifications, and options available for the unit. The introduction also provides information on the use and description of the MOORE INDUSTRIES model numbering system.

**Section 2, Calibration**, provides all the information necessary to calibrate the unit before installation. This section contains a list of the tools necessary for calibrating the equipment; and illustrates the test setups essential to perform that task. The section also lists the various procedures required for calibration of the units in any configuration.

**Section 3, Installation and Operation**, supplies all the information needed to install and operate the equipment. The section contains figures that specify the installation requirements for the units, and text that informs the user on recommended wiring practices for the equipment. It also defines the electrical connections for each unit regardless of physical modifications. A brief outline of periodic inspections required during the equipment operation is also included here.

**Section 4, Theory of Operation**, gives the maintenance personnel a detailed explanation of the internal function of the unit. The circuit theory is based on a block diagram that shows the functional elements of the unit. Each element operation is then described, first in relation to the other elements, then independently where its major components' use and purpose are described.

**Section 5, Maintenance**, offers complete disassembly procedures for all unit configurations available. Troubleshooting information is also provided in this section as well as component replacement techniques to aid the technician in the repair of the equipment.

**Section 6, Unit Documentation**, acquaints the user with the MOORE INDUSTRIES computerized parts listing and identification system. The section also provides a recom-

mended spare parts list. All schematics and parts assembly drawings referred to by the text are located in the back of Section 6.

## 1.2 EQUIPMENT DESCRIPTION

The SRX is a two wire transmitter, that operates from a 4-20 MA loop, and performs linear flow measurement by extracting the square root of the signal, and producing a 4-20 MA output.

## 1.3 STANDARD UNIT PHYSICAL DESCRIPTION

The SRX consists of a printed circuit board, (PC1) that contains the electronic components required to perform the square root extraction, and a small vertical board, (PC2), to provide plug-in connections and mounting for the adjustment potentiometers.

The boards are enclosed in an oval protective housing (HP). Electrical connections information is given in Section 3, Installation and Operation.

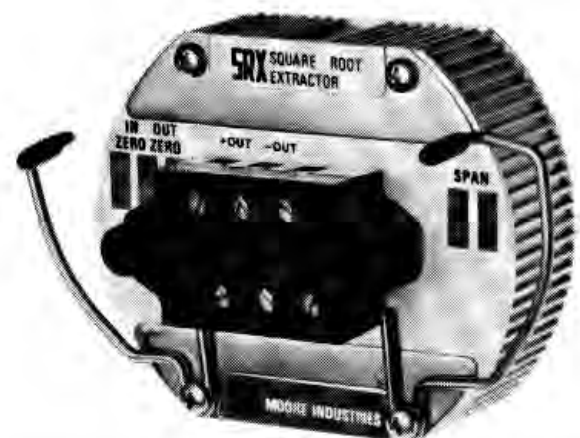

FIGURE 1-1  
(HP) HOUSING

#### 1.4 EXPLOSION-PROOF UNIT, PHYSICAL DESCRIPTION

The explosion-proof enclosure option consists of the standard enclosure described in paragraph 1.3, inserted into a two-piece cast aluminum alloy enclosure. The two pieces consist of a screw-type cover and a housing with hubs. The standard enclosure is modified mechanically, to allow mounting of the HP housing into the explosion-proof housing. The modification consists of an additional spring assembly that wedges the standard unit into place.



FIGURE 1-2  
EXPLOSION — PROOF HOUSING

#### 1.5 RF UNIT PHYSICAL DESCRIPTION

The RF unit option consists of standard SRX electronics with the addition of an RF filter input. This additional electronic process requires some mechanical modifications to the input connections. An RF filter replaces the standard input connector, with input and output connections being effected through a flex cable wired between the PC board and the filter. This configuration mechanically fastens the housing cover to the PC board; thus both assemblies must be removed together for maintenance.

#### 1.6 SERIAL NUMBER USE AND LOCATION

A complete history is kept on every MOORE INDUSTRIES unit. This information is keyed to the serial number. Whenever service data is required on a unit, it is necessary to provide the factory with a serial number as well as a model number (see paragraph 1.7 for location on the equipment).

#### 1.7 MODEL NUMBER EXPLANATION AND USE

MOORE INDUSTRIES' model numbers describe an instrument's type, functional characteristics, operating parameter, and include option identification. If all accompanying documentation of a unit is missing, the model number may be used to obtain technical information on the unit by following the example of Table 1-2. The model number for standard units is located on the identification label on the cover. For explosion-proof units, the model number is stamped on a stainless steel tag on top of the enclosure.

TABLE 1-1 UNIT SPECIFICATIONS

##### INPUT:

Range: 4-20mA

Source: differential pressure transmitter

##### ADJUSTMENT:

Input Zero: Adjusts the output to 10% with an input current at 1% of span.

Output Zero: Adjusts the output to 50% with an input current at 25% of span.

Span: Adjusts the output to 100% with an input current at 100% of span.

OUTPUT: 4-20mA into 300 OHMS, based on 12vdc d/p transmitter and 24 volts loop power.

Linearity:  $\pm 0.1\%$  of span above 1% of input.

##### AMBIENT TEMPERATURE:

Range:  $-28^{\circ}\text{C}$  to  $+82^{\circ}\text{C}$

( $-20^{\circ}\text{F}$  to  $+180^{\circ}\text{F}$ )

Effect:  $< +.01\%/^{\circ}\text{F}$  above 10% of input.

$< +.025\%/^{\circ}\text{F}$  from 5-10% of input.

POWER: Current loop excitation 4mA @ 6.0 vdc

##### LOAD RESISTANCE:

$$R_{\text{Max}} = \frac{V_{\text{supply}} - 6 \text{ vdc} - V_{\text{input}}}{20\text{MA}}$$

$$V_{\text{Supply}} = 24 \text{ vdc based on average voltage supplied}$$

$$V_{\text{Input}} = 12 \text{ vdc, based on average d/p transmitter}$$

##### OPTIONS:

RF Patented terminal strip with filters and ground plane for RFI/EMI protection, exceeds SAMA standard.

LV Low Voltage option, provides current loop excitation of 4mA @ 5.5 vdc. Selection of this option voids reverse polarity protection.

##### HOUSINGS:

HP Aluminum case, for conduit mounting by customer.

FL Aluminum case (HP) with mounting flanges

EX Explosion proof enclosure for Class I, Groups C & D; Class II, Groups E, F, G; and Class III environments.  
Crouse-Hinds GUJ series conduit ®

CERTIFICATION: Canadian Standards Association applied for

WEIGHT: 141.5 grams (5 oz), without EX enclosure  
1.36 kilograms (3 lb), approximate, with EX enclosure

ORDERING INFORMATION: Specify the following

1. Unit Type
2. Input
3. Output
4. Options
5. Housing

##### SAMPLE MODEL NUMBER:

SRX/4-20MA/4-20MA/6DC/-RF [FL]

**TABLE 1-2 MODEL NUMBER EXAMPLE**

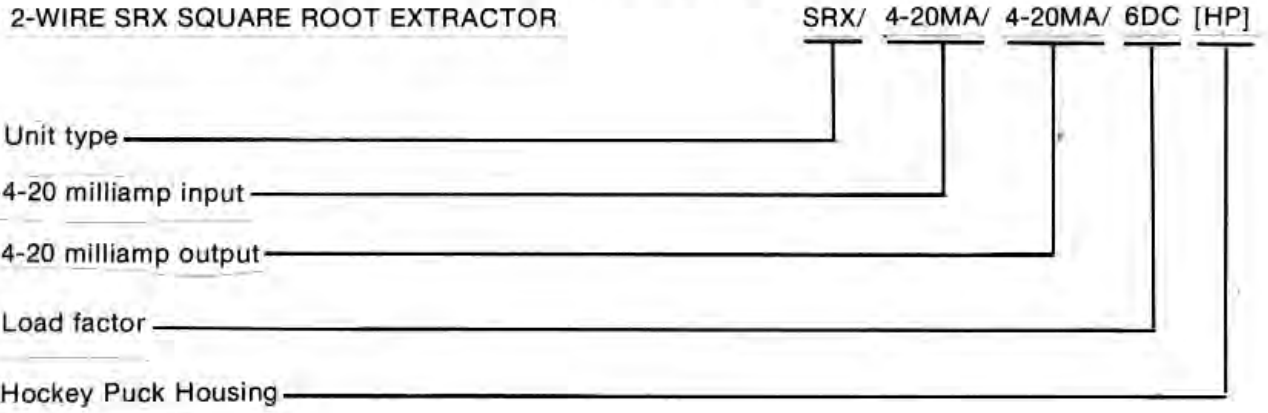

**TABLE 1-3. ELECTRICAL OPTIONS**

OPTION DESCRIPTION	CODE
RFI — Filter terminal assembly prevents radio frequency energy from entering case	-RF
-LV—Low voltage option, provides excitation @ 5.5vdc. Selection of this option voids the Reverse Polarity Protection.	-LV

## 2.1 GENERAL INFORMATION

This section provides information about unit calibration. Units with standard input and output levels are normally calibrated at the factory. After the unit is unpacked, general operating level checks are recommended. Usually these checks, specified in this section under calibration procedures, require little or no adjustments. If units are ordered with factory calibration option (FC), an exact calibration is performed at the factory. Adjustments should not be made in the field on these units unless a new range of input or output signal level is desired.

## 2.2 CONTROLS DESCRIPTION AND LOCATION

The controls consist of potentiometer adjustments, located on the unit front panel. The multiturn potentiometers, are adjusted with a blade screwdriver.

### CAUTION

USE BLADE SCREWDRIVER NOT MORE THAN 0.1 INCH (2.54 mm) WIDE. USE OF A WIDER BLADE MAY PERMANENTLY DAMAGE THE POTENTIOMETER MOUNTING.

This type of potentiometer usually requires 20 turns of the shaft to move the wiper from one end of its range to the other. It is equipped with a slip clutch at either end of its travel to prevent damage

if it is turned beyond the wiper stop. Usually a slight change in feel will be noticed when the clutch is slipping. However, if this change is not observed, either end can be reached by turning the shaft 20 turns in the desired direction. Controls are connected, so turning the shaft clockwise increases the quantity or makes it more positive, and turning the shaft counterclockwise has the opposite effect.

## 2.3 TEST EQUIPMENT AND TOOLS REQUIRED

Test equipment and tools required for calibration of the unit are described in Table 2-1; they are not supplied and must be provided by the customer at the installation or test site.

## 2.4 TEST EQUIPMENT SETUPS

Off-line calibration of all units require the same test equipment setups regardless of option or physical configuration. The hookup requirements and physical preparations may vary on some units. The following paragraphs define the general test setup and identify the units that require special attention for test preparation and connections.

Figure 2-1 shows the general test setup configuration. Note that in the explosion-proof configuration the protective housing must be opened and the unit removed to expose the connection block.

TABLE 2-1. TEST EQUIPMENT AND TOOLS REQUIRED

Equipment or Tool	Characteristic	Purpose
Screwdriver (blade)	Blade no wider than 0.1 inch (2.54 mm)	Front panel control adjustment
Adjustable DC Signal Source	Must be accurate to within $\pm 0.05\%$ or better	Simulates input signal
DC Milliammeter	Must be accurate to within $\pm 0.05\%$ or better	Output signal monitoring

## 2.5 CALIBRATION OF UNITS

Units are calibrated and checked for proper performance at the factory before they are shipped. However, unless calibration was requested to a specific set of input-output values, the unit performance should be checked by the user before the unit is placed in service. Calibration consists of simulating the operative signal input and adjusting the unit to obtain the specified output.

An adjustable input signal source and input and output monitoring devices are required for calibration. The monitoring devices must have an accuracy within  $\pm 0.05\%$  or better. To calibrate a unit, proceed as follows:

- a. Connect the unit to the test equipment as shown in Figure 2-1.
- b. Apply power to the unit under test.

### NOTE

Refer to Table 1-2 for information on how to use the model number to obtain the specified values of minimum and maximum inputs and outputs.

- c. Adjust the input signal source to a value 1% above the live zero value, or 4.16mA.
- d. Adjust the input zero potentiometer to obtain an output value 10% greater than the live zero input, or 5.6mA.
- e. Reset the input signal source to 8.0mA, to represent a value 25% greater than the live zero.
- f. Adjust the output zero potentiometer to obtain an output reading of 12.0mA.
- g. Set the input signal source to 16.96mA (81%).
- h. Adjust the SPAN potentiometer to obtain an output signal of 18.4mA (90%).
- i. Repeat the previous steps as required until no further adjustment of input zero, output zero, or span potentiometers is necessary.
- j. Remove the input signal source, and remove power from the unit under test.

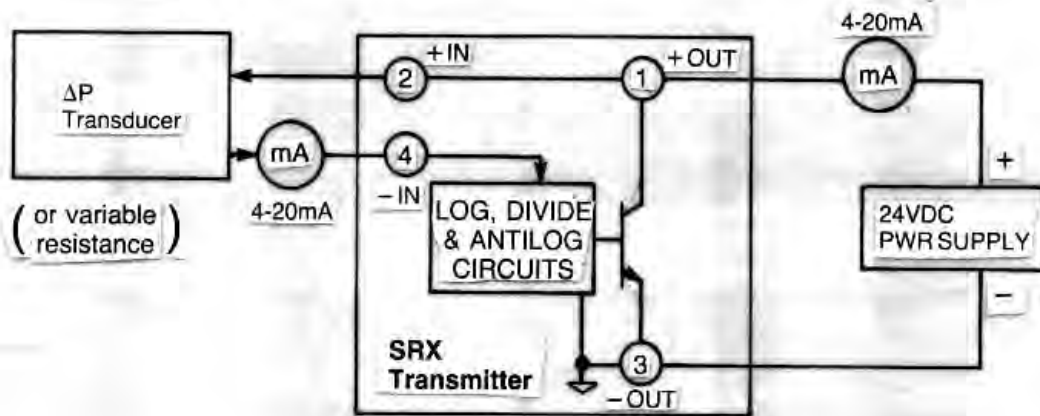

**Figure 2-1**  
**HOOKUP DIAGRAM FOR ADJUSTMENT/  
CALIBRATION OF SRX TRANSMITTER**

### 3.1 MECHANICAL INSTALLATION

Units may be obtained in various physical configurations. Figures 3-1 and 3-2 show the outline dimensions and other installation requirements for the available configurations. Select the proper outline and dimension figure applicable to the unit purchased. Be sure to observe the applicable special procedures and precautions given with the illustration. Although the units are designed to operate in free air at quite a high ambient temperature, it is advisable, if possible, to mount the unit on a surface made of material that can serve as a heat sink.

### 3.2 ELECTRICAL CONNECTIONS

All electrical connections to standard units are made to the connector on the unit. Terminals used for standard units and their options are defined in the following paragraph.

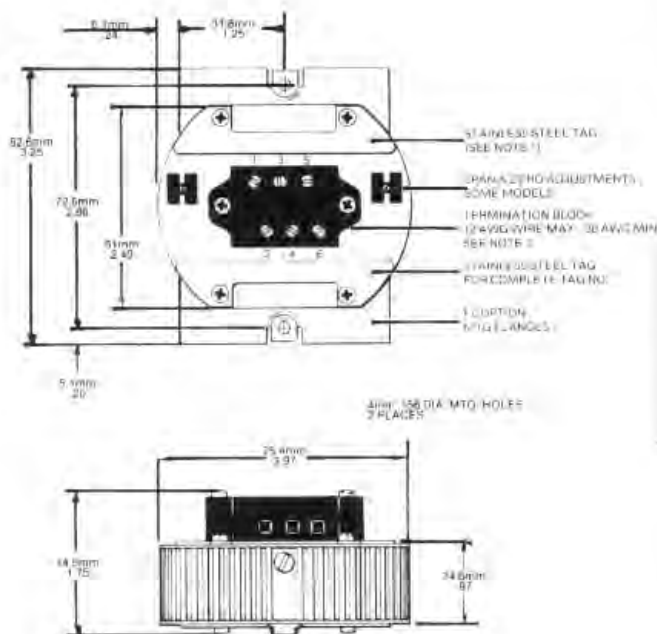

**FIGURE 3-1  
STANDARD UNIT & DIMENSIONS**

### 3.2.1 General Wiring Information

No special wire or cable is required for signal connections to the unit. To avoid transients and stray pickups, it is recommended that twisted conductors be used where they are run close to other services (such as power wiring).

*Wiring Information for Standard Units.* Figure 3-3 illustrates the connector pin locations and identification for the standard units. Table 3-1 provides the complete labeling nomenclature for the units. Terminal labeling appears next to the terminal it identifies on standard units. For explosion-proof units, terminal labeling is marked on the unit housing with the referenced terminals identified numerically.

*Wiring Information for All Explosion-Proof Units.* Units mounted in explosion-proof boxes are standard units with or without the options listed in Table 3-1. Dress all wiring to and from terminals through conduit openings.

### 3.2.2. Power Connections

Units are designed to operate directly from a DC current source. Terminals 1 and 3 are designated as output with terminals 2 and 4 assigned as input.

### 3.3 OPERATION AND PERIODIC OBSERVATION

Once calibrated and installed, the unit may be operated unattended. There are no indicators on the unit. Because the circuit uses highly reliable solidstate components with no moving parts, the unit should operate virtually maintenance-free for a long period of time. However, if a malfunction should occur, refer to Section 5 for maintenance information.

A periodic check of input and output connections is recommended every six months to ensure continued dependability of operation.

A unit may become warm during operation, especially where the ambient temperature is rather high. This is perfectly normal and should not be a cause for alarm unless a malfunction is also observed.

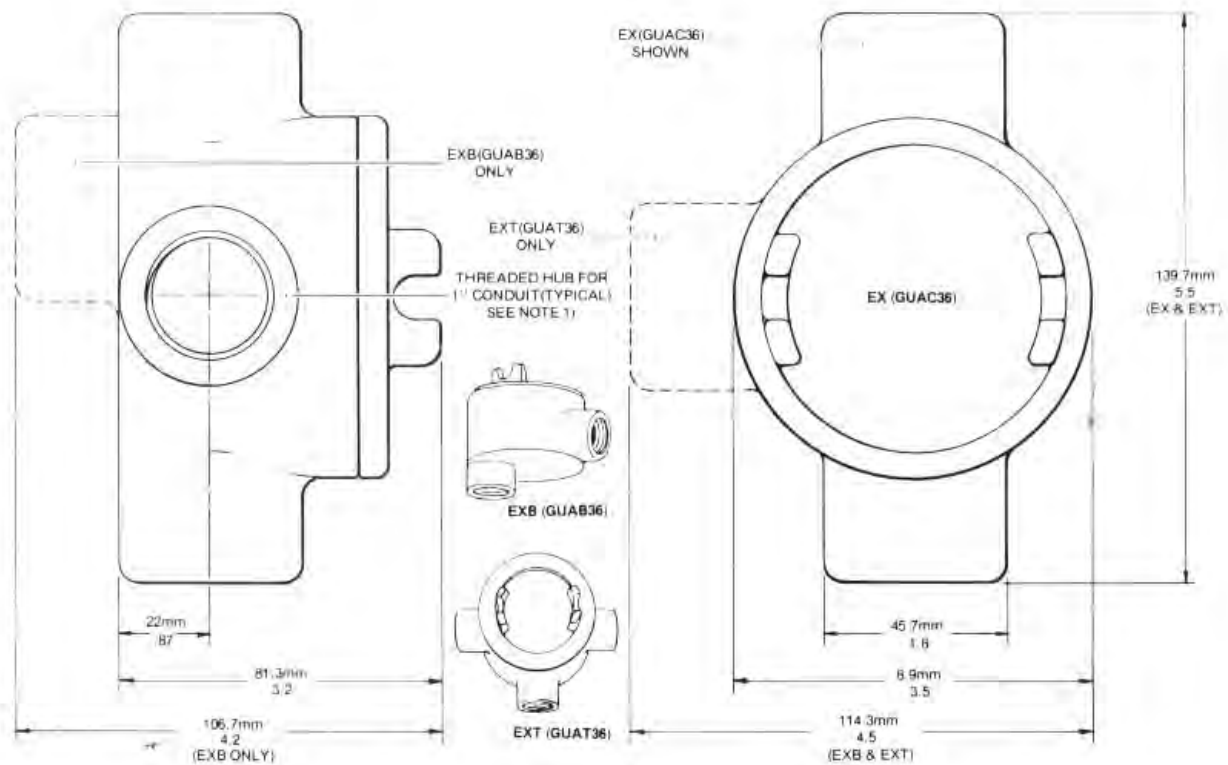
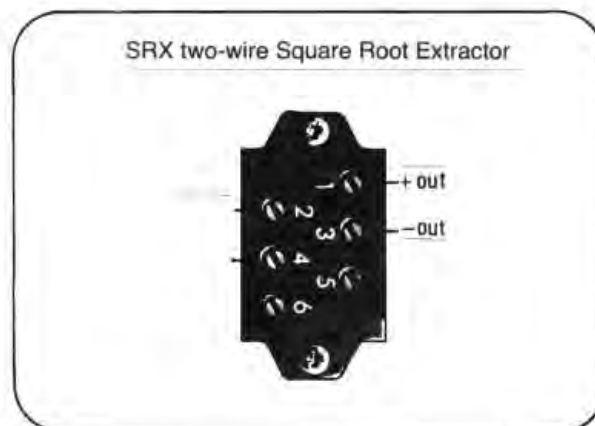

**FIGURE 3-2**

**STANDARD UNIT IN EXPLOSION-PROOF ENCLOSURE, OUTLINE AND DIMENSIONS**

**TABLE 3-1  
TERMINAL NOMENCLATURE**

Options	Terminal Positions					
	1	2	3	4	5	6
NONE	+OUT	+IN	-OUT	-IN	—	—
RF	+OUT	+IN	-OUT	-IN	—	—



**FIGURE 3-3  
TERMINAL POSITIONS**



## 4.1 INTRODUCTION

This section describes the unit operation. An overall view of the unit function based on the block diagram of Figure 4-1 introduces the user to the unit functional elements. This functional analysis is further detailed in the circuit description paragraphs that follow. These descriptions are based on the schematic diagram included in Section 6, Unit Documentation.

Familiarization of the unit can be obtained by reading the general functional description (paragraph 4.2). Detailed circuit descriptions provide sufficient data so that troubleshooting, if required, can be performed intelligently and rapidly.

## 4.2 GENERAL FUNCTIONAL DESCRIPTION

The SRX is a two wire transmitter that performs linear flow measurement by extracting the square root of the input signal and producing a 4-20 MA output.

The unit consists of a power supply section, function generator circuits, and an output section.

## 4.3 POWER SUPPLY CIRCUIT

Operational amplifier IC3, and the associated components R17, R18, R19, R21, and zener diode CR4, form the power supply section. (Refer to schematic drawing in section 6)

Resistors R17 and R21, form a divider network to produce 2 volts of direct current that is applied to the inverting input, pin 2, of the voltage regulator IC3. Feedback for the regulator is developed across the divider network of R18 and R19, which is applied to pin 8 of the regulator. The reference voltage produced by IC3 is held constant by the zener action of CR4 which acts as a current sink to maintain the 2 volt reference.

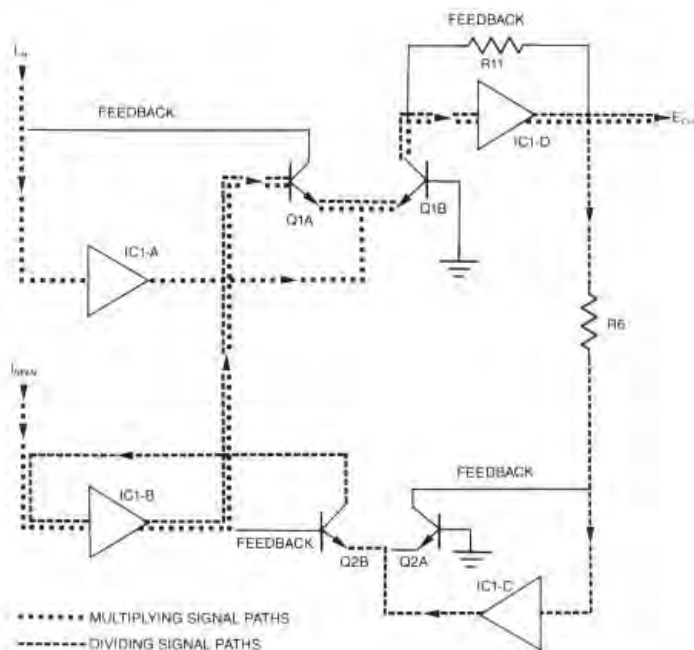

FIGURE 4-1 BLOCK DIAGRAM

#### 4.4 DESCRIPTION OF FUNCTION GENERATION CIRCUIT

Shaping of the output voltage or current curve is accomplished by the Function Generation Circuit. The Function Generation Circuit, mounted on printed circuit board PC1, is comprised of IC1, transistors Q1, Q2 and associated components. Figure 4-2 is a simplified schematic of the function generator, showing the multiplication signal path and the division signal path.

The multiplication function is performed when the  $I_{in}$  signal and the  $I_{span}$  signal are applied through IC1-A, and B, respectively, then across the junction of Q1A and Q1B to generate a logarithmic output voltage which is the product of the linear inputs. Negative feedback for IC1-A, is derived from the output signal, pin 1, of IC1 and applied to the emitter of Q1A. This provides collector current from Q1A that is equal to the varying input signal at pin 2 of IC1-A.

The logarithmic output, derived from Q1, is applied to the inverting input of IC1-D, pin 13, with negative feedback being generated across R11 to produce the  $E_{out}$  signal.

Division is accomplished, by taking the  $E_{in}$  signal and dividing this by the value of  $E_{out}$ . The output signal from pin 14 of IC1 is applied across R6 to the inverting input, pin 9 of IC1-C. The output, pin 8, is applied to the common emitter junction of Q2 which forms an antilog circuit. The signal at the collector of Q2A, provides a negative feedback path to IC1-C, while the collector signal of Q2B provides feedback to pin 6 of IC1-B. The output signal at pin 7 of IC1-B is applied to the base of Q1A, which effects the inverting input of IC1-D, pin 13.

#### 4.5 OUTPUT CIRCUIT

The signal derived from the function generator, is applied across R15, to the non-inverting input, pin 3 of IC2. The output signal, at pin 6 of this op-amp, controls the conduction of Q3 to provide a signal that is proportional to the d/p input.

Since the value of R11 and the resistance of  $I_{span}$  are constant, the following functions are derived from the circuit.

$$E_{out} = \frac{I_{in}}{E_{out}}$$

$$I_{in} = E_{out} \times E_{out}$$

$$E_{out} = \sqrt{I_{in}}$$

#### 4.6 LOW VOLTAGE OPTION

Since the SRX is a loop powered device, live zero or 4 mA excitation is normally set at 6.0 vdc. In some cases loop resistance may require a lower excitation point, which may be realized by specifying the -LV, or low voltage option. This option provides excitation at 5.5 vdc but deletes the Reverse Polarity Protection of the transmitter. When the -LV option has been selected, care should be exercised to ensure proper polarity of connections.

## 5.1 INTRODUCTION AND GENERAL INFORMATION

This section contains information to aid in the maintenance of the unit. This includes disassembly instructions for all mechanical options, as well as general troubleshooting. Precautions and special techniques required to replace a component are also described.

## 5.2 DISASSEMBLY

When unit troubleshooting is required, it is first necessary to disassemble the unit. The physical configuration of the unit determines the steps to be followed in disassembly. These are described in the following paragraphs.

### NOTE

Always identify wires — usually by tagging — before disconnecting existing connections.

### CAUTION

DISCONNECT INPUT SIGNAL AND REMOVE POWER INPUT BEFORE DISASSEMBLING UNIT.

### 5.2.1 Disassembly of Standard Unit

To disassemble a standard unit, remove the unit from its installed position. After the unit has been removed from its installed position, disassemble the unit as follows to gain access to the circuit board.

- a. Tag and disconnect wires from unit.
- b. Remove four cover-mounting Phillips-head screws at top of unit.
- c. Using appropriate screwdriver, loosen Phillips-head screw on the side of the mounting.
- d. Remove two connector mounting screws on unit cover and plug. Free connector from the PC board.

### 5.2.2 Disassembly of Units in EX Enclosures

Use the following procedure to disassemble unit:

- a. Using a bar wrench, attach to wrench lugs, and loosen the housing cover from the base.
- b. Disconnect wires from unit connector.

- c. A spring clip secures the unit inside the conduit.® Squeeze the sides of the clip inward, and lift the entire unit out of the conduit.®
- d. Gain access to unit internal wiring by using the procedure of paragraph 5.2.1. When replacing unit into casing, ensure that one of the flat sides of the hockey puck housing is facing the hubs that carry the external wiring.

## 5.3 TROUBLESHOOTING

The schematic diagrams include flagged numbers at various points in the circuit. Table 5-1 gives the voltages and waveforms at these points for specified input-signal conditions. The assembly drawing shows the physical locations of the parts on the circuit board. Bear in mind that the circuit board is protected with a moisture-resistant coating. Therefore, it may be necessary to use a needle-point probe and exert a fair amount of pressure to break through the coating when it is desired to observe the signal or voltage at a specific point. When connecting a probe to a component on the circuit board, exercise care to make sure the probe does not short-circuit to an adjacent component.

In general, troubleshooting is carried out by tracing the signal with an oscilloscope and referring to the schematic diagrams to determine what component might be causing an observed abnormal indication. If the original symptom was a complete failure of the unit to operate, the most logical components to suspect are those associated with the constant current supply in the unit (including any voltage regulators). If the unit is producing an incorrect (but not zero) output, check the outputs from the input circuit and trace the resulting signal through the unit.

### 5.3.1 Plug-In Board Connector Cleaning

Occasionally, modules which have been in service for a long period of time may develop resistive coatings on the gold-plated contacts of the plug-in boards. This coating, if allowed to build up, may cause malfunctions by decreasing the noise margin of a circuit.

There are two types of foreign material coatings which can develop on the gold-plated contacts of a plug-in module. The first type is INORGANIC. This type of contamination results when copper "bleeds" through the gold plating and oxidizes.

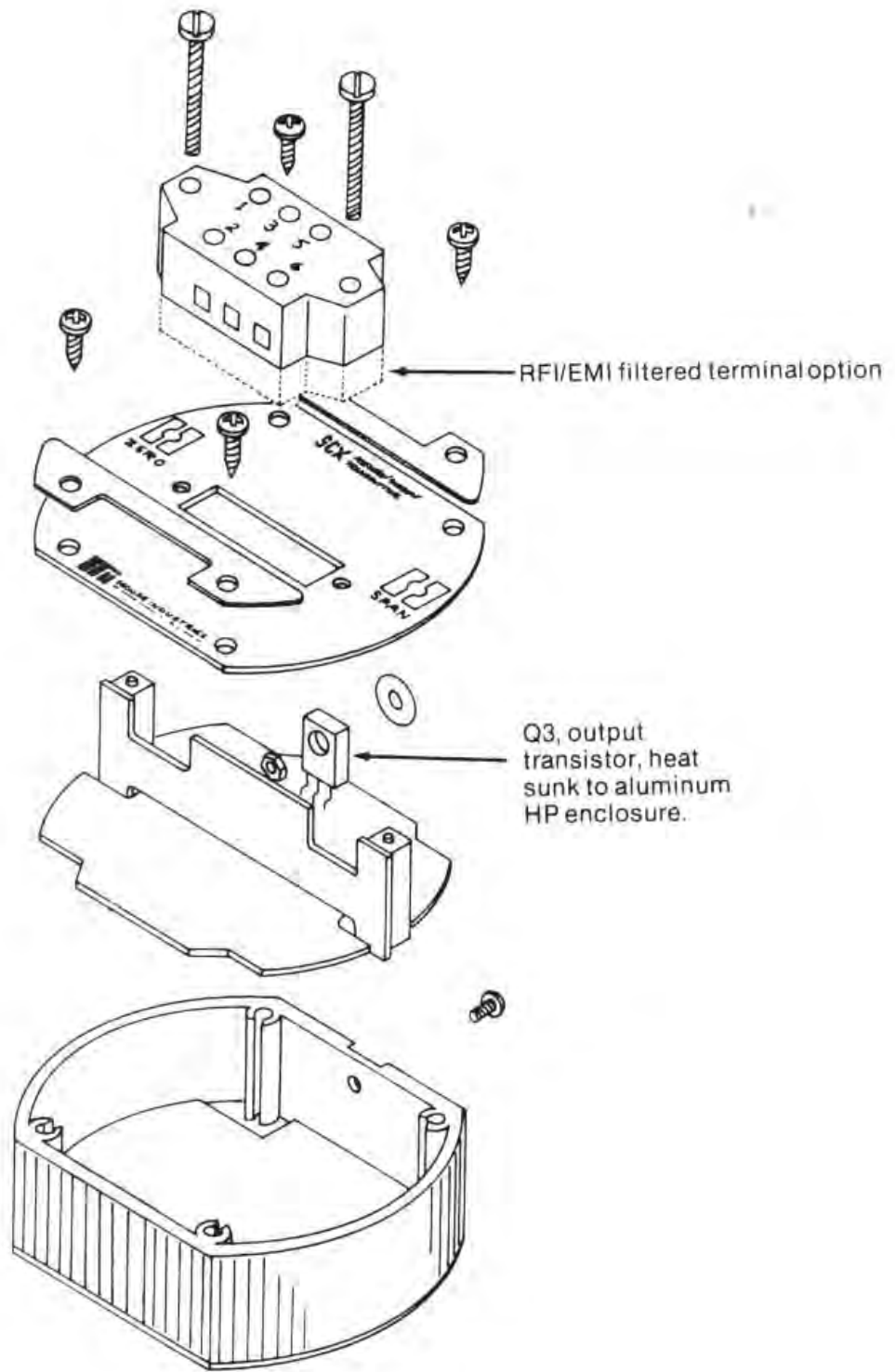

**FIGURE 5-1  
EXPLODED VIEW OF HP**

The second form of contamination involves ORGANIC substances, which usually are a result of careless handling, and are mainly made up of fingerprints, salts, and oils deposited when the plug-in boards are handled by the gold-plated contacts. Contamination by organic substances can be greatly reduced by careful handling of the modules.

Although connectors are usually of the self-cleaning type, it may become necessary to clean the module fingers to ensure reliable connection. When contacts are in need of cleaning, the following procedures are recommended:

*Removal of Inorganic Contaminants:*

- a. Immerse contacts of plug-in board in an ultrasonic bath of deionized water and a detergent such as Liquinix, for at least 30 seconds.
- b. Repeat step (a) with pure deionized water only.

**CAUTION**

REMOVE WATER IMMEDIATELY FROM CONTACTS. IF THIS IS NOT DONE QUICKLY DAMAGE TO CONTACTS MAY RESULT.

- c. Remove water by immersing contacts in an ethane or methanol bath to same depth used during the ultrasonic cleaning of step (a). Never wipe or use an abrasive cleaner on the contacts. If wiping is necessary, use K-Dry towels or equivalent.

*Removal of Organic Contaminants:*

- a. After inorganic contaminants and water have been removed, organic materials may be removed by immersion of contacts in trichloroethane for at least 30 seconds.

**CAUTION**

NEVER USE AN ERASER ON THE CONTACTS. THE USE OF ABRASIVE CLEANERS OR ERASERS ON PLUG-IN BOARD CONTACTS IS CONSIDERED A PHYSICAL ABUSE TO UNIT AND MAY VOID THE UNIT WARRANTY.

- b. Let contacts air dry or wipe with a very fine, nonabrasive material such as K-Dry towels or equivalent.



**5.3.2 Component Replacement General Information**

Replace all defective components with identical parts. Refer to Section 6 for a list of recommended replacement parts. The last row of numbers in the parts list is the number of spares recommended to be kept on hand for that part, per unit, for up to ten units of the same type. For more than ten units, a spares complement of 10% on the indicated parts should be used.

**5.3.3 Component Replacement Techniques**

Most parts used in the unit are quite small and are

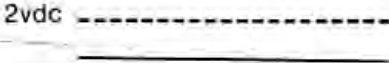
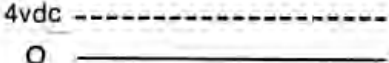
**TABLE 5-1. WAVEFORMS OR VOLTAGES**

TEST POINT	WAVEFORM OR VOLTAGES
1	2vdc 
2	4vdc  0 
3	4 MA = 2.0 vdc 20 MA = 2.29 vdc
4	REFERENCE

located in a confined area. Therefore, small hand tools are a necessity when servicing the unit. The following is a summary of the general techniques and precautions that should be observed to prevent damage to components in the unit:

- a. Use a transformer-operated low-voltage soldering iron with a grounded tip and rated at not more than 50 watts. A temperature controlled tip is desirable.
- b. Use extreme care when unsoldering the leads to any component. Do not keep the soldering iron on a point for more than a few seconds at a time. Use a suction-type solder-removing tool (solder sucker) as an aid in unsoldering transistors and integrated circuits. The protective coating on the unit may be removed

with trichloroethane or equivalent. Be sure adequate ventilation is provided when using this or any other chemical.

- c. Do not excessively bend or twist the leads of small components; they break easily.
- d. Before removing a component, observe the lead dress. Be sure that the lead dress of the replacement is the same as that of the original.
- e. Remove all flux from soldered joints with trichloroethane or equivalent.
- f. Test the unit for proper operation and, if necessary, recalibrate by the procedure given in Section 2.

## 6.1 GENERAL

This section consists of a computer print-out table that provides parts identification information for the unit. Wiring lists have been provided in this section as an aid to the maintenance personnel.

Parts information is grouped according to the number of assemblies. If the unit contains two PC boards, the table will be divided into two major sections: one section will contain information related to PC1 and the other section will list PC2 components information. Each major section in the table contains a complete parts list headed LIST OF MATERIALS specifying which PC board it is describing. This list of materials consists of the following headings:

**ITEM:** A reference numeral used for data processing and not used by maintenance personnel.

**NAME:** Gives the nomenclature of the part.

**DESCRIPTION:** Identifies the component by manufacturer's part number, usually followed by component's parameters or value.

**REF:** Lists the reference designation for the component, referred to in Section 4, on the schematic and assembly drawings.

**PART NUMBER:** This column specifies the Moore Industries assigned part number. This is the part identification required when ordering parts from Moore Industries.

**SPARE:** The numeral in this column specifies the recommended number of component spares per unit type that should be kept on hand by maintenance personnel.

## 6.2 GLOSSARY OF ABBREVIATIONS

C	Capacitor
CR	Diode — zener included
HW	Special hardware
J	Connecting buss wire
L	Inductor
LB	Label
PC	Printed circuit board
R	Resistor
T	Transformer
IC	Integrated circuit
Q	Transistor
LED	Light emitting diode
TB	Terminal block
VS	Voltage regulating varistor
VR	Voltage regulator



**MOORE INDUSTRIES**  
16650 Schoenborn Street  
Sepulveda, California 91343

**DO NOT SCALE DRAWING**

**TOLERANCES**  
UNLESS NOTED  
.X ±.1  
.XX ±.03  
.XXX ±.010  
ANGLES ±30°

DRAWN	2 AUG 79
CHECKED	2-7-79
ENGINEER	
SCALE	NONE

SRX  
PCI & PC2

DRAWING NUMBER

110-401-00

REVISION

C

CATEGORY

SCHEMATIC

REVISED BY

ECO4955

DATE

15 SEP 82

BY

D

APPROVAL

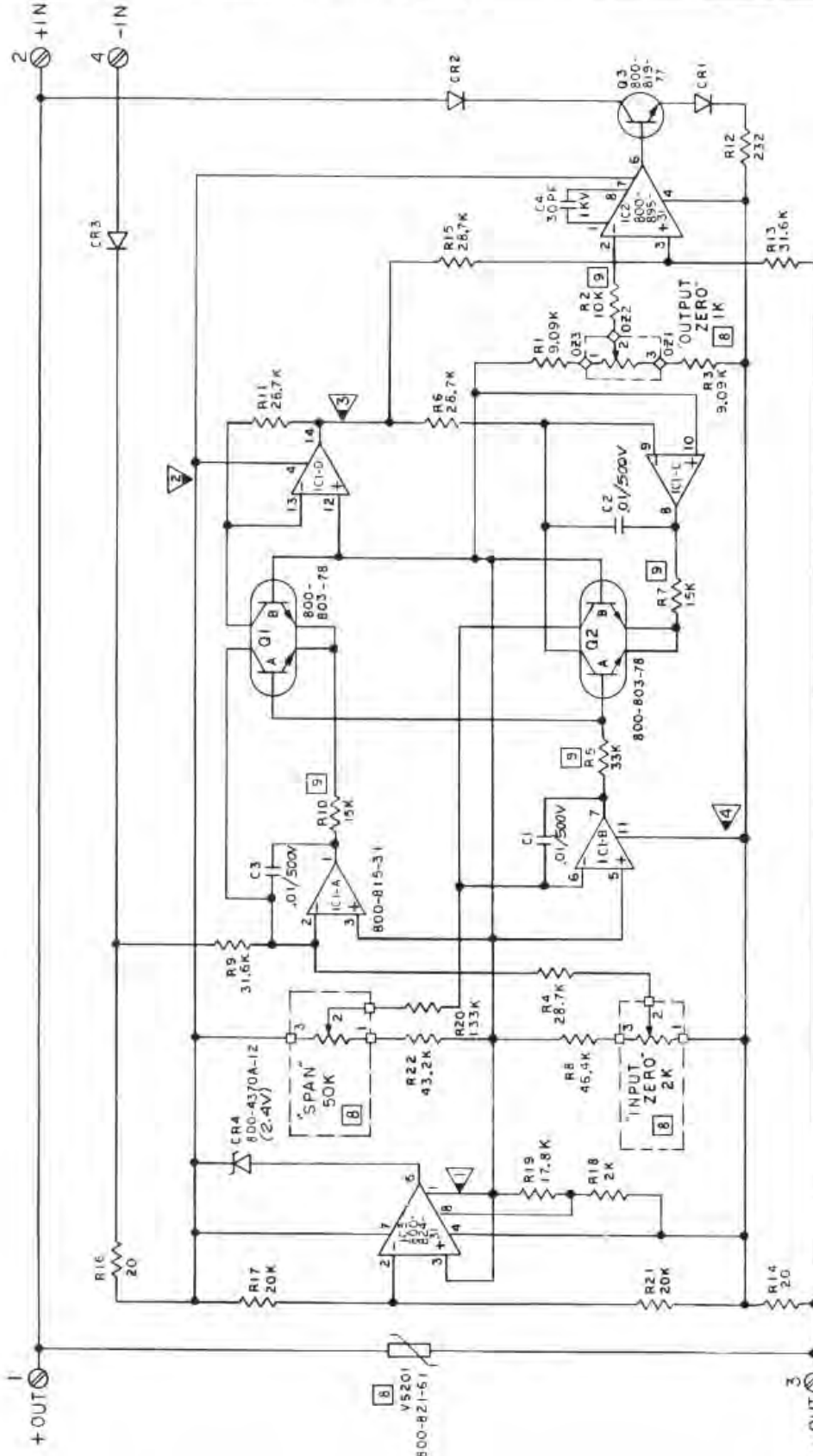

- 10. INDICATES TEST POINT, FILLED END IS POINTER; SEE SECTION 5 OF MANUAL, "MAINTENANCE".
  - CARBON COMP RESISTOR (RC07GF) ±5% TOL, 1/4W.
  - COMPONENT LOCATED ON PC2.
  - 7. INDICATES PCI/PC2 INTERCONNECT PIN.
  - 5. INDICATES IDENTIFIED WIRE PAD.
  - 4. INDICATES SCREW TERMINAL.
  - 3. POTENTIOMETERS INCREASE CLOCKWISE FROM PIN 1 TO PINS 3. (DELETED)
  - 2. DIODES ARE INM/48, RESISTORS ARE METAL FILM, RN55C, ±1% TOL, 1/8 W.
  - 1. RESISTANCE VALUES ARE IN OHMS, CAPACITANCE IN MICROFARADS (UF).
- NOTES: UNLESS OTHERWISE SPECIFIED:



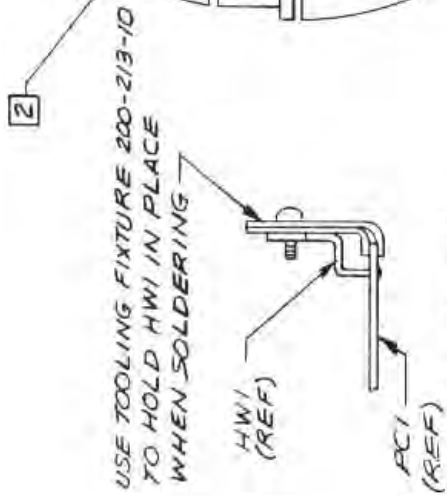
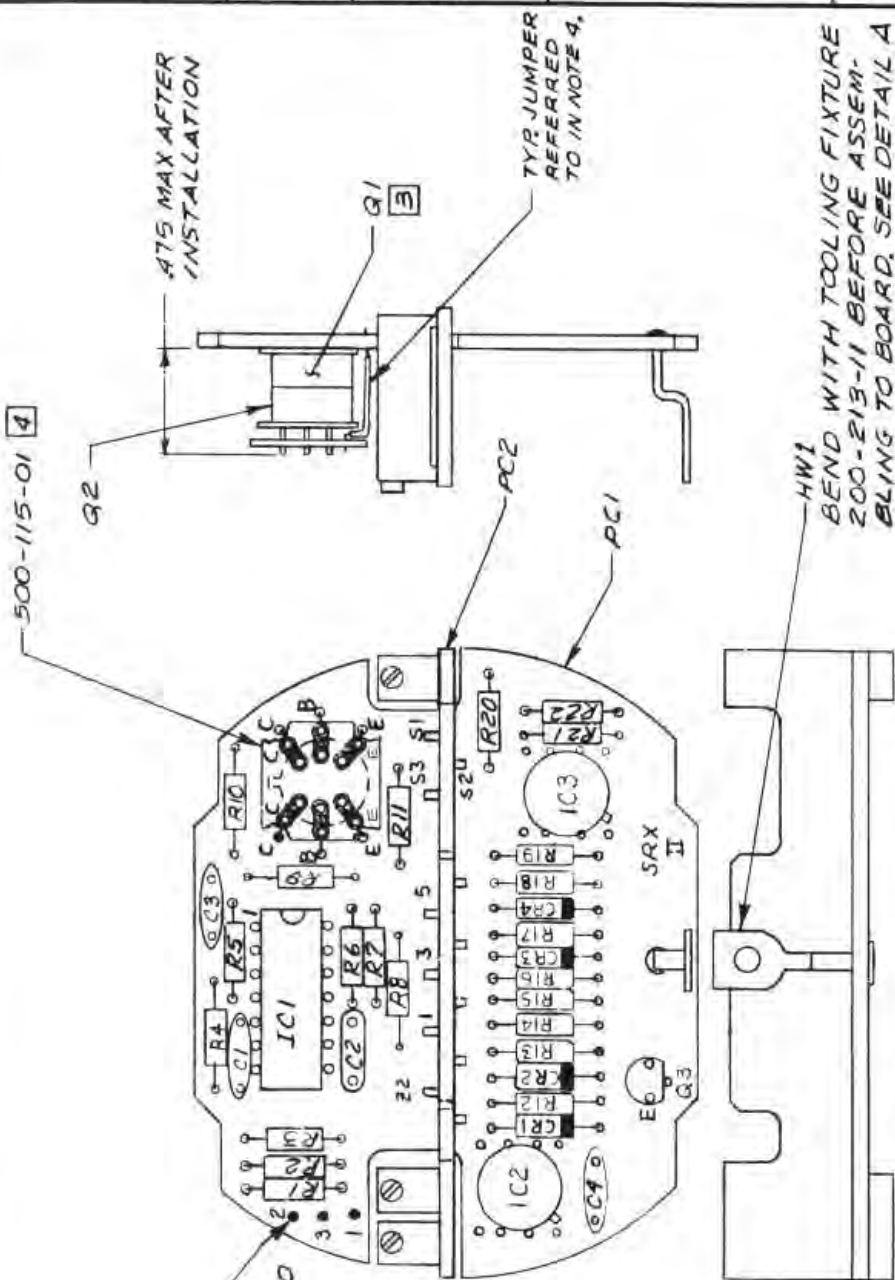

- 4 INSTALL OVER Q2, SOLDER IN PLACE TO DIMENSION SHOWN, JUMPER TO PC1 PAD C TO C, B TO B, E TO E. (22AWG, TEFLON INS), 6 PLACES.
- 3 G1 & Q2 TO BE GLUED TOGETHER WITH PERMA-BOND BEFORE MTG TO PC1.
- 2 WIRE PADS 1, 2, 3 TO BE JUMPERED TO PC2 WIRE PADS 1, 2, 3. (22AWG, TEFLON INS).
1. ALL LEADS TO BE SOLDERED TO PADS.
- NOTES:

BEND WITH TOOLING FIXTURE 200-213-11 BEFORE ASSEMBLING TO BOARD. SEE DETAIL A



**MOORE INDUSTRIES**  
 16650 Schoenborn Street  
 Sepulveda, California 91343

DO NOT SCALE DRAWING

TOLERANCES  
 UNLESS NOTED  
 X ± .1  
 XX ± .03  
 XXX ± .010  
 ANGLES ± 30°

DATE: 2-7-80  
 DESIGNED: RRE  
 CHECKED: [Signature]  
 AUG 77  
 SCALE: 2/1

SRX  
 PC2

110-502-00  
 ASSEMBLY  
 INITIAL RELEASE  
 BY: JAD  
 DATE: 80

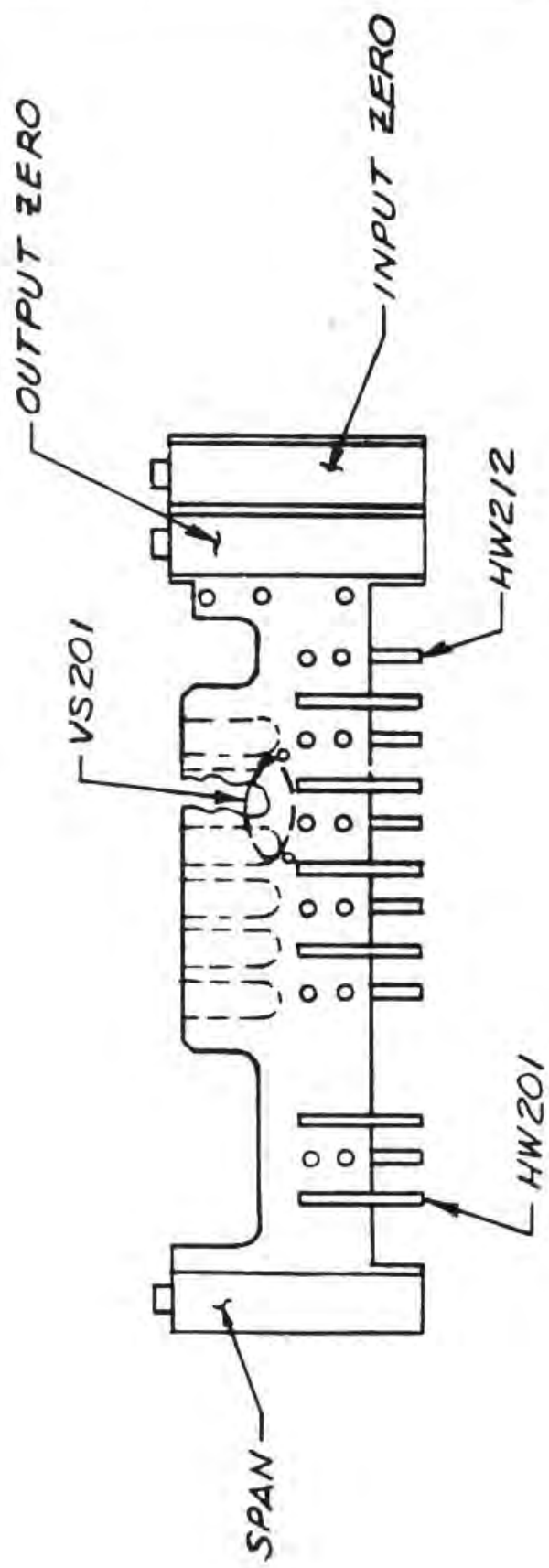

1. ALL LEADS TO BE SOLDERED TO PADS.  
 NOTES:



**MOORE INDUSTRIES**

19 050 S. ... Street  
... 93343

DO NOT SCALE DRAWING

TOLERANCES  
UNLESS NOTED

X ±1  
XX ±.03  
XXX ±.010  
ANGLES ±30°

*Dr. ...*

2-7-80

*TRC*

2/1

110-504-00

ASSEMBLY

INITIAL RELEASE *ZFB*

JAD

*MR*

SRX -RF

PC2

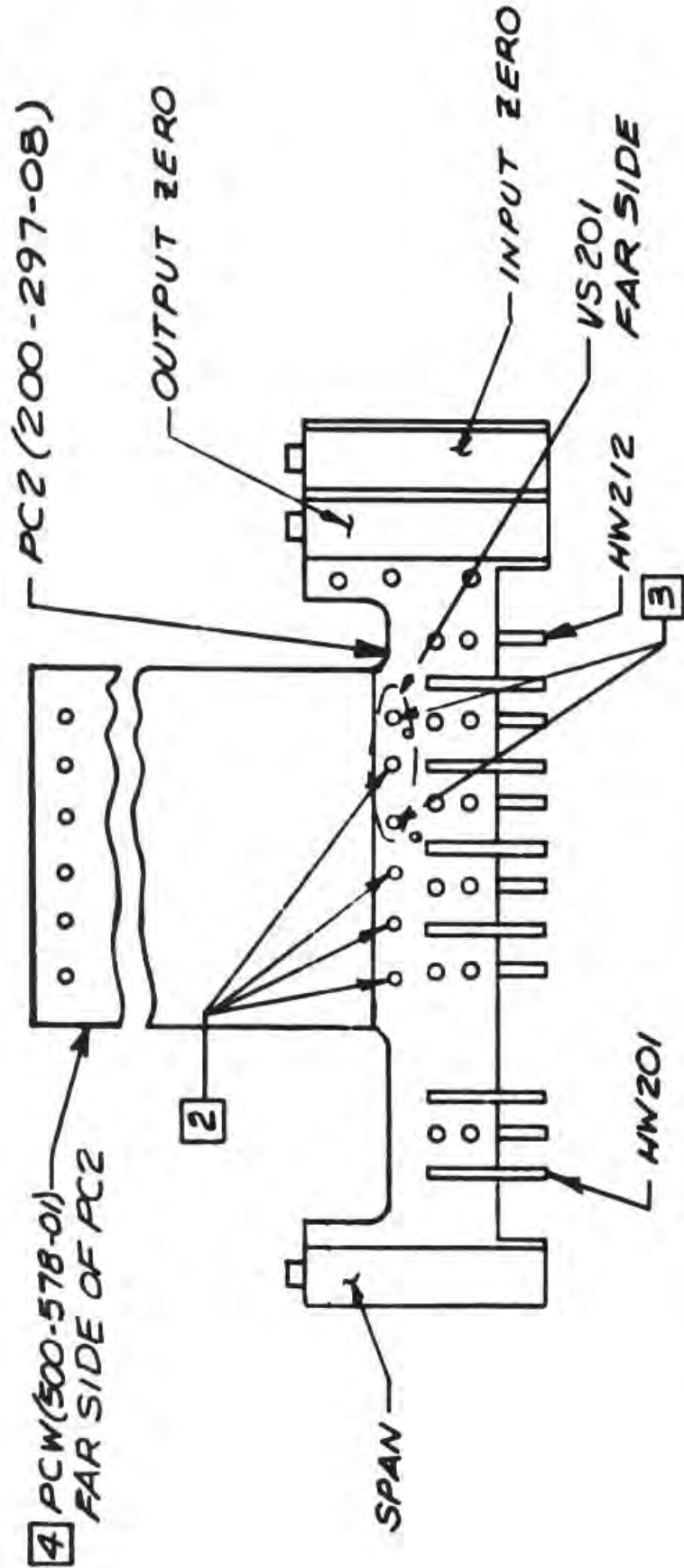

- 4 INSTALL WITH EXPOSED COPPER AREAS FAR SIDE.
  - 3 INSTALL VS201 LEADS THRU PC2 & PCW; SOLDER NEAR SIDE OF PC2 & FAR SIDE OF PCW.
  - 2 INSTALL 22AWG BUSS WIRE THRU PC2 & PCW; SOLDER NEAR SIDE OF PC2 & FAR SIDE OF PCW.
1. DO NOT TRIM EXCESS FROM HW201 THRU HW212.
- NOTES:

DO NOT SCALE DRAWING		
TOLERANCES UNLESS NOTED	DRAWN R Kelly	7/2/73
X ±.1	CHECKED	
XX ±.03		
XXX ±.010		
ANGLES ±.3°		
SCALE		

SRX DIN  
PCI & PC2

DRAWING NUMBER	110-405-00	REVISION	5
CATEGORY	SCHEMATIC		
DESIGNED BY	ECO 5276	DATE	7/14/73
APPROVED BY		BY	RK
		APPROVAL	X

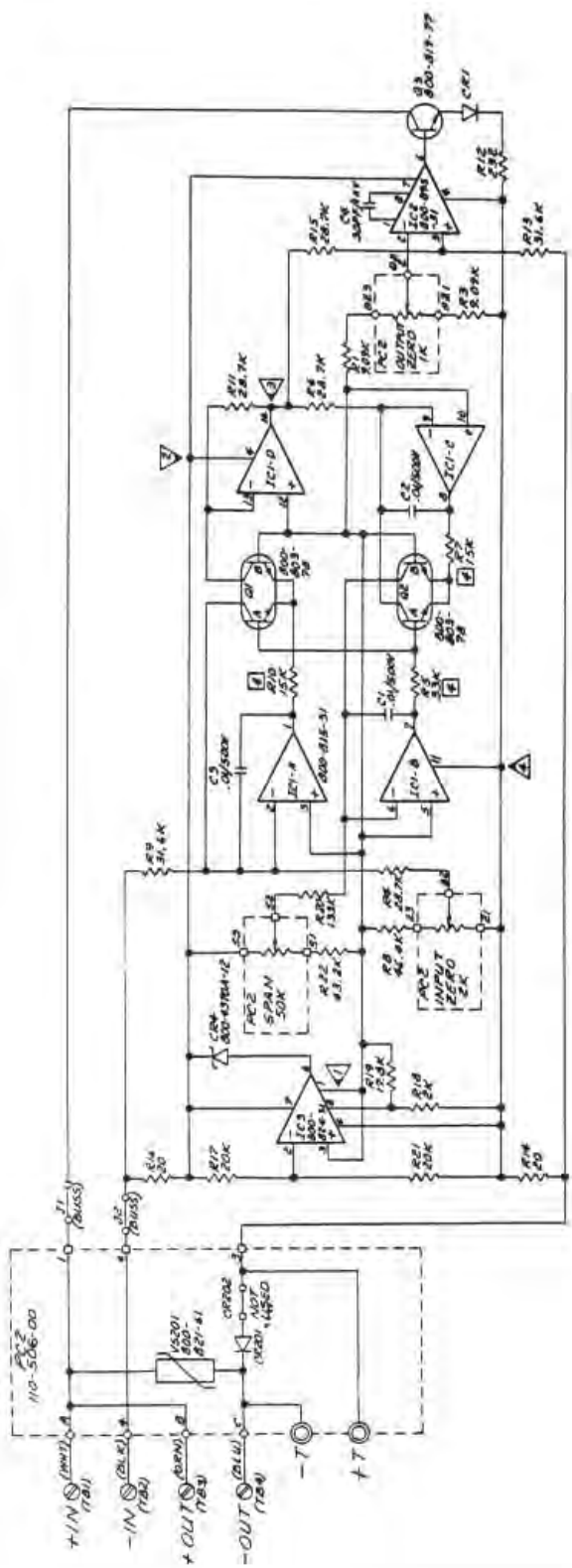

- 1) TEST JACK ON FRONT PANEL FOR .080 INCH TIP PROBE.
- 2) DRY/WET INTERCONNECT PIN.
- 3) DRY/WET INTERCONNECT PIN.
- 4) DRY/WET INTERCONNECT PIN.
- 5) TEST POINT, FILLED END IS POSITIVE, REFER TO SECTION 5 OF MANUAL, MAINTENANCE.
- 6) 500 OHM TERMINAL CONNECTION.
- 7) 11 INDIATORS INCREASE CLOCKWISE FROM 1 TO 3.
- 8) 100 OHM COMP RESISTOR (R7070) = 100, 1/4 W.
- 9) ALL DIODES ARE 800 M14B-11 (SMA14).
- 10) ALL RESISTORS ARE METAL FILM (RNS55) 1/2 W. 1% W.
- 11) 10 INCHES IN DIMS; CAPACITANCE IN MICRO/FARADS.
- 12) 1.5 UNLESS OTHERWISE SPECIFIED.



**MOORE INDUSTRIES**  
16650 Schoenborn Street  
Sepulveda, California 91343

<b>DO NOT SCALE DRAWING</b>	
TOLERANCES UNLESS NOTED	DRAWN <i>P. Kelley</i> 7/83
X ± .1	CHECKED
XX ± .03	DRAWN
XXX ± .010	SCALE 2:1
ANGLES ± 30°	

**SRX DIN  
PCI**

DRAWING NUMBER	110-505-00	REVISION	E
CATEGORY	ASSEMBLY		
HYDRO BY	ECO 5276	DATE	7/83
		BY	RK
		APPROVED	BL

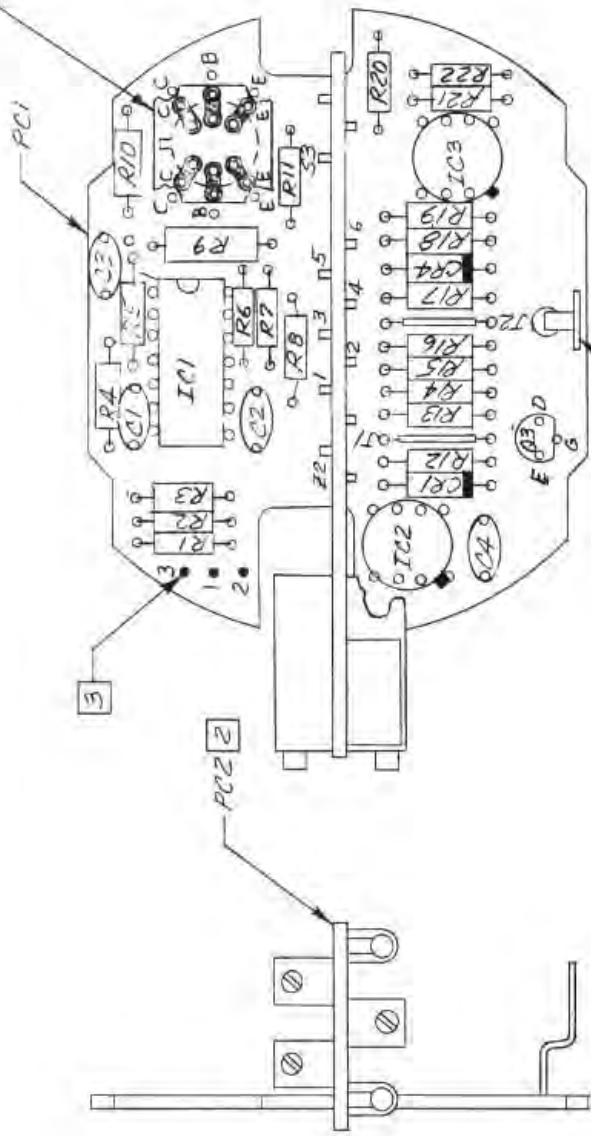
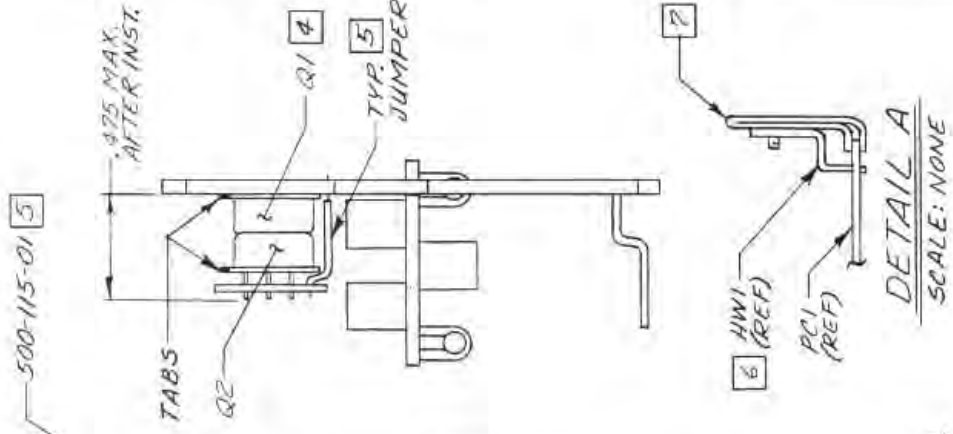

7. USE FIXTURE 200-213-10 TO HOLD HWI WHILE SOLDERING.
6. USE FIXTURE 200-213-11 TO BEND HWI.
5. INSTALL OVER Q2, SOLDER IN PLACE AS SHOWN, JUMPER TO PCI PAD 'C' TO 'E', 'B' TO 'B', 'E' TO 'E'. (BEANG, TEFLON INS.) 6 PLACES.
4. Q1 & Q2 TO BE GLUED TOGETHER WITH PERMABOND BEFORE MTG TO PCI.
3. WIRE PADS '1, 2, 3' TO BE JUMPERED TO P22 PADS "QZ1, QZ2, QZ3". (BEANGS, TEFLON INS.).
2. P22 MUST SIT FLAT ON & PERPENDICULAR TO PCI.
1. ALL LEADS TO BE SOLDERED TO PADS.

NOTES:



**MOORE INDUSTRIES**  
16650 Schoenborn Street  
Sepulveda, California 91343

DO NOT SCALE DRAWING

TOLERANCES  
UNLESS NOTED  
X ± 1  
XX ± 03  
XXX ± 010  
ANGLES ± 30

DRAWN R. Kelley 9/83  
CHECKED  
INCHES  
TITLE 2-1

SRX DIN  
PC2

DRAWING NUMBER

110-506-00

REVISED

B

CATEGORY

ASSEMBLY

REVISED BY

ECO 5276

DATE

11/7/83

BY

R. K.

APPROVED

TK

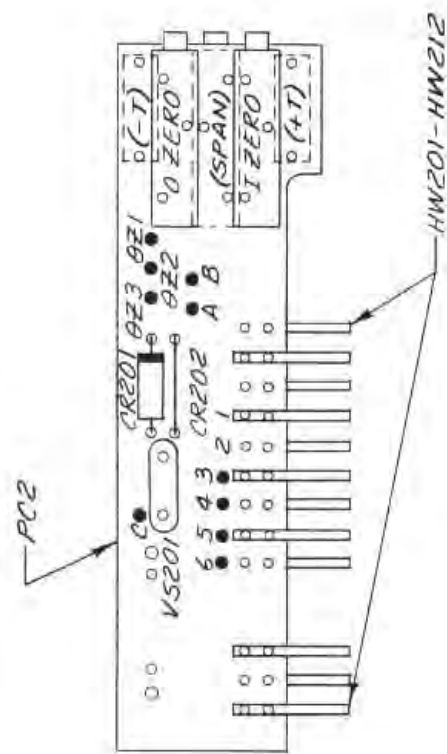
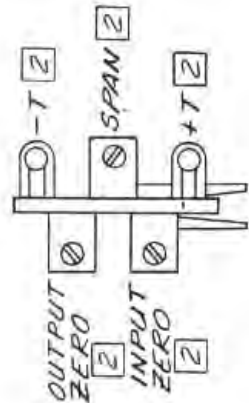

2 SPAN, INPUT ZERO, OUTPUT ZERO, +T & -T MUST MOUNT FLAT ON BOARD.  
1. ALL LEADS TO BE SOLDERED TO PADS.  
NOTES:

# RETURN PROCEDURES

## To return equipment to Moore Industries for repair, follow these four steps:

1. Call Moore Industries and request a Returned Material Authorization (RMA) number.

### Warranty Repair –

If you are unsure if your unit is still under warranty, we can use the unit's serial number to verify the warranty status for you over the phone. Be sure to include the RMA number on all documentation.

### Non-Warranty Repair –

If your unit is out of warranty, be prepared to give us a Purchase Order number when you call. In most cases, we will be able to quote you the repair costs at that time. The repair price you are quoted will be a "Not To Exceed" price, which means that the actual repair costs may be less than the quote. Be sure to include the RMA number on all documentation.

2. Provide us with the following documentation:
  - a) A note listing the symptoms that indicate the unit needs repair
  - b) Complete shipping information for return of the equipment after repair
  - c) The name and phone number of the person to contact if questions arise at the factory
3. Use sufficient packing material and carefully pack the equipment in a sturdy shipping container.
4. Ship the equipment to the Moore Industries location nearest you.

The returned equipment will be inspected and tested at the factory. A Moore Industries representative will contact the person designated on your documentation if more information is needed. The repaired equipment, or its replacement, will be returned to you in accordance with the shipping instructions furnished in your documentation.

### WARRANTY DISCLAIMER

THE COMPANY MAKES NO EXPRESS, IMPLIED OR STATUTORY WARRANTIES (INCLUDING ANY WARRANTY OF MERCHANTABILITY OR OF FITNESS FOR A PARTICULAR PURPOSE) WITH RESPECT TO ANY GOODS OR SERVICES SOLD BY THE COMPANY. THE COMPANY DISCLAIMS ALL WARRANTIES ARISING FROM ANY COURSE OF DEALING OR TRADE USAGE, AND ANY BUYER OF GOODS OR SERVICES FROM THE COMPANY ACKNOWLEDGES THAT THERE ARE NO WARRANTIES IMPLIED BY CUSTOM OR USAGE IN THE TRADE OF THE BUYER AND OF THE COMPANY, AND THAT ANY PRIOR DEALINGS OF THE BUYER WITH THE COMPANY DO NOT IMPLY THAT THE COMPANY WARRANTS THE GOODS OR SERVICES IN ANY WAY.

ANY BUYER OF GOODS OR SERVICES FROM THE COMPANY AGREES WITH THE COMPANY THAT THE SOLE AND EXCLUSIVE REMEDIES FOR BREACH OF ANY WARRANTY CONCERNING THE GOODS OR SERVICES SHALL BE FOR THE COMPANY, AT ITS OPTION, TO REPAIR OR REPLACE THE GOODS OR SERVICES OR REFUND THE PURCHASE PRICE. THE COMPANY SHALL IN NO EVENT BE LIABLE FOR ANY CONSEQUENTIAL OR INCIDENTAL DAMAGES EVEN IF THE COMPANY FAILS IN ANY ATTEMPT TO REMEDY DEFECTS IN THE GOODS OR SERVICES, BUT IN SUCH CASE THE BUYER SHALL BE ENTITLED TO NO MORE THAN A REFUND OF ALL MONIES PAID TO THE COMPANY BY THE BUYER FOR PURCHASE OF THE GOODS OR SERVICES.

ANY CAUSE OF ACTION FOR BREACH OF ANY WARRANTY BY THE COMPANY SHALL BE BARRED UNLESS THE COMPANY RECEIVES FROM THE BUYER A WRITTEN NOTICE OF THE ALLEGED DEFECT OR BREACH WITHIN TEN DAYS FROM THE EARLIEST DATE ON WHICH THE BUYER COULD REASONABLY HAVE DISCOVERED THE ALLEGED DEFECT OR BREACH, AND NO ACTION FOR THE BREACH OF ANY WARRANTY SHALL BE COMMENCED BY THE BUYER ANY LATER THAN TWELVE MONTHS FROM THE EARLIEST DATE ON WHICH THE BUYER COULD REASONABLY HAVE DISCOVERED THE ALLEGED DEFECT OR BREACH.

### RETURN POLICY

For a period of thirty-six (36) months from the date of shipment, and under normal conditions of use and service, Moore Industries ("The Company") will at its option replace, repair or refund the purchase price for any of its manufactured products found, upon return to the Company (transportation charges prepaid and otherwise in accordance with the return procedures established by The Company), to be defective in material or workmanship. This policy extends to the original Buyer only and not to Buyer's customers or the users of Buyer's products, unless Buyer is an engineering contractor in which case the policy shall extend to Buyer's immediate customer only. This policy shall not apply if the product has been subject to alteration, misuse, accident, neglect or improper application, installation, or operation. THE COMPANY SHALL IN NO EVENT BE LIABLE FOR ANY INCIDENTAL OR CONSEQUENTIAL DAMAGES.



**WORLDWIDE • www.miinet.com**

United States • info@miinet.com Tel: (818) 894-7111 • FAX: (818) 891-2816	Belgium • info@mooreind.be Tel: 03/448.10.18 • FAX: 03/440.17.97	China • sales@mooreind.sh.cn Tel: 86-21-62491499 • FAX: 86-21-62490635
Australia • sales@mooreind.com.au Tel: (02) 8536-7200 • FAX: (02) 9525-7296	The Netherlands • sales@mooreind.nl Tel: (0)344-617971 • FAX: (0)344-615920	United Kingdom • sales@mooreind.com Tel: 01293 514488 • FAX: 01293 536852